

4 Rotation and Reflection Groups

1. Notice that the original dihedral group had twice as many elements as the rotation group. Why?

(Answers may vary.)

There are a couple ways to think about this, but an intuitive way is to consider a “mirror world” of reflection and the “normal world” where the orientation is normal. Here, orientation is not absolute orientation, but the difference between clockwise and counterclockwise. For chemistry nerds, it is like chirality. Rotation preserves orientation, but reflection does not. Instead, it takes us between these two “worlds.” Thus, it allows twice the number of elements.

2. Make and justify a conjecture extending this observation to the dihedral groups of other shapes like rectangles, squares, and hexagons, as well as the symmetry group of the cube.

(Answers may vary.)

Conjecture: The dihedral groups of a shape has twice the order of its rotation group.

Informal justification: A shape can be flipped or not, and it can have whatever rotational isometries applied to it whether it's flipped or not. Thus, the dihedral group allows for twice the number of elements as the rotation group.

3. Let r be a 180° rotation, x be a reflection over the x -axis, and y be a reflection over the y -axis. Write a table for the dihedral group of the rectangle, recalling that the allowed isometries are reflections and rotations. How does this table differ from the dihedral group of the equilateral triangle?

\cdot	I	r	x	y
I	I	r	x	y
r	r	I	y	x
x	x	y	I	r
y	y	x	r	I

The table is shown above. The four elements are shown acting on a rectangle with “P” painted on it in Figure 1 to show the transformation a bit better.

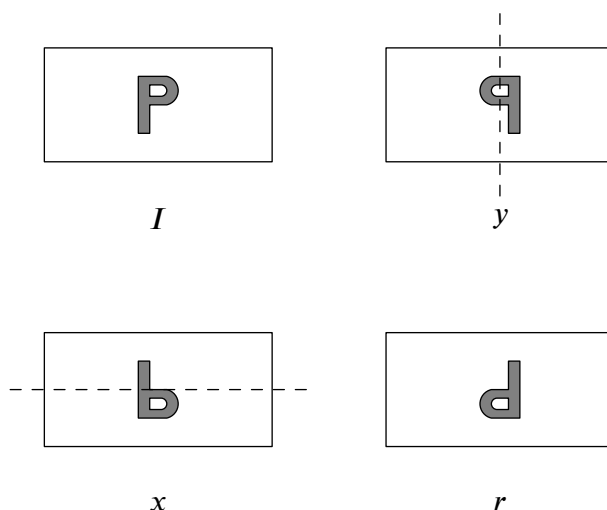

Figure 1: A rectangle joyously rotates and flips around.

This differs from the dihedral group of the equilateral triangle, D_3 , in several ways. The most obvious is that there are only 4 elements. Also, all elements besides I in this group have a period of 2, while D_3 has two elements with a period of 3.

4. Write a table for the rotation group of the square, with 4 elements and 16 entries. Compare this table to Problem 3.

\cdot	I	r	r^2	r^3
I	I	r	r^2	r^3
r	r	r^2	r^3	I
r^2	r^2	r^3	I	r
r^3	r^3	I	r	r^2

The elements are $I = r_0$, $r = r_{90}$, $r^2 = r_{180}$, and $r^3 = r_{270}$. The table is shown above.

While this has the same order as the rectangle's dihedral group, it has a different structure. There are two elements with period 4 (r, r^3) and one element with period 2 (r^2).

For each of the following problems, find the following:

- The number of elements, also known as the **order** or **cardinality**
- If order < 10 , name the set of elements; otherwise, explain how you know the order
- A smallest possible **generating set**; in other words, a list of elements which generate a group²
- Whether the group is **commutative**; in other words, whether its operation \cdot satisfies $X \cdot Y = Y \cdot X$ for all X, Y

5. Rectangle under rotation

(a) Number of elements

This group has two elements: the identity and the rotation of 180° .

(b) If order < 10 , the set of elements; otherwise, an explanation of how you know the order

As stated, they are the identity I and the rotation r of 180° , as shown in Figure 2.

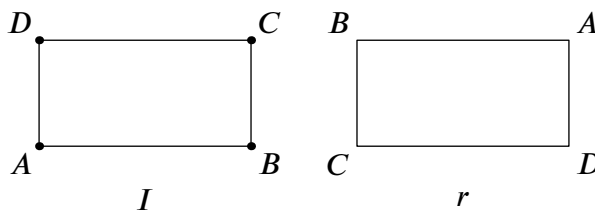

Figure 2: Rectangle under rotation.

(c) A smallest possible generating set

The smallest possible generating set is the singleton $\{r\}$.

(d) Whether the group is commutative

The group is commutative, since it only contains rotations, which commute.

6. Rectangle under reflection

We already considered this group in Problem 3.

(a) Number of elements

There are 4 elements in this group.

(b) If order < 10 , the set of elements; otherwise, an explanation of how you know the order

The elements are the identity I , rotation r by 180° , reflection x over the x axis, and reflection y over the y axis.

(c) A smallest possible generating set

²There may be multiple generating sets of the same size.

(Answers may vary.)

$\{r, x\}$, $\{r, y\}$, and $\{x, y\}$ all generate the group. No single element, however, can generate the group, because it is not a cyclic group.

(d) Whether the group is commutative

This group may be manually verified to be commutative.

7. Square under rotation

Again, we have considered this group before.

(a) Number of elements

There are 4 elements.

(b) If order < 10 , the set of elements; otherwise, an explanation of how you know the order

The elements are rotations $I = r_0$, $r = r_{90}$, $r^2 = r_{180}$, and $r^3 = r_{270}$.

(c) A smallest possible generating set

(Answers may vary.)

Both $\{r\}$ and $\{r^3\}$ generate the group. r^2 alone cannot generate the group, as it cannot achieve r or r^3 .

(d) Whether the group is commutative

The group is commutative, since it is a cyclic group.

8. Square under reflection

(a) Number of elements

There are 8 elements in this group. We can quickly see this by noting that it is the dihedral group of the square, which has twice the order of the rotation group of the square. We just found that had 4 elements, and $2 \cdot 4 = 8$.

(b) If order < 10 , the set of elements; otherwise, an explanation of how you know the order

The elements are as follows:

Rotations $I = r_0$, $r = r_{90}$, $r^2 = r_{180}$, and $r^3 = r_{270}$; reflections $f = \text{flip over the } x\text{-axis}$, $fr = r$ then f , fr^2 and fr^3 .

Recall that rotations can be generated by a sequence of two reflections.

Each of these elements is shown in Figure 3.

(c) A smallest possible generating set

(Answers may vary.)

Any pair of a rotation and flip will generate the set, except for $\{r^2, fr^2\}$ and $\{r^2, f\}$; these will produce the rectangle group instead. Any pair of two flips, except for $\{f, fr^2\}$, will also work. As an example of both of these categories, both $\{r^2, fr^3\}$ and $\{f, fr\}$ will generate the group. A single element cannot generate the whole group, because the group is not cyclic.

(d) Whether the group is commutative

This group is not commutative. For example, $fr = fr$, but $rf = fr^3$.

9. Square prism under rotation

This group is isomorphic to the dihedral group of the square in Problem 8.

(a) Number of elements

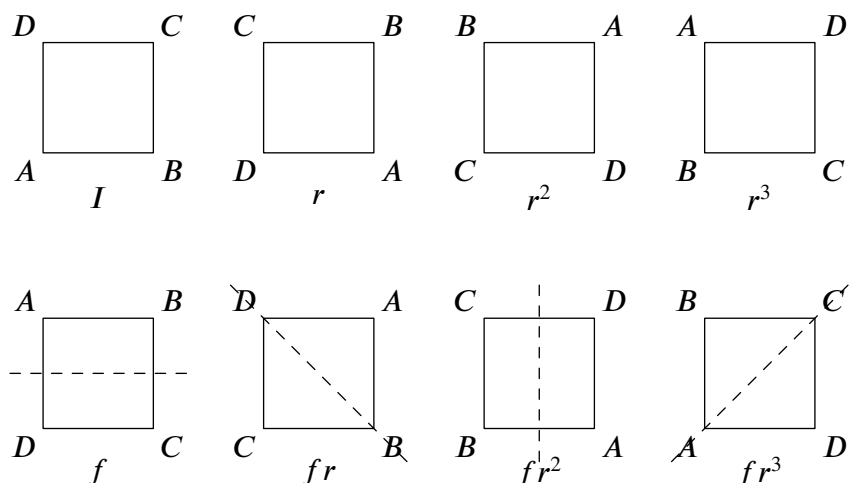

Figure 3: Reflections of a square.

This question is a bit more difficult than the previous questions. We can rotate the prism about its central axis, which is an action analogous to just rotating a square: 4 elements. But we can also rotate the prism 180° on an axis through the middle (pictures are shown in the next part). This action switches the top square face with the bottom face, giving another 4 elements. In total, therefore, we have 8 elements.

(b) If order < 10 , the set of elements; otherwise, an explanation of how you know the order

The set of elements are shown in Figure 4 below. Let a be a rotation of 90° counterclockwise—as viewed from the top—around the central axis, going through the centers of both square faces; let b be a rotation of 180° around an axis going through the centers of faces $\square ABB'A'$ and $\square DCC'D'$.

(c) A smallest possible generating set

(Answers may vary.) The elements with b in their name are equivalent to the reflections in the dihedral group of the square. Thus, we need a “reflection” ba^n and a rotation a^m , or two separate reflections. All such pairs work except for $\{a^2, ba^2\}$, $\{a^2, b\}$ and $\{b, ba^2\}$. An example from each category: $\{a, b\}$, $\{b, ba\}$.

(d) Whether the group is commutative

This group is not commutative. For example, $ab = ba^3 \neq ba$, so a and b do not commute.

10. Square prism under reflection

(a) Number of elements

If the previous group—the rotation group of the square prism—had 8 elements, then this group should have $2 \cdot 8 = 16$ elements.

(b) If order < 10 , the set of elements; otherwise, an explanation of how you know the order

We know the order because the previous group has 8 elements, and dihedral groups have twice the number of elements of the rotation group, this group has 16 elements.

(c) A smallest possible generating set

(Answers may vary significantly.)

Since we could generate the previous group with (most) pairs of $\{ba^n, a^m\}$, or (most) pairs of $\{a^n, a^m\}$, we could just add another element c which is a true geometric reflection about, say, the midplane P between $\square DCD'C'$ and $\square ABB'A'$ as shown in Figure 5.

Thus, $\{a, b, c\}$ can generate the group. You can *prove* that two generators are impossible, but the proof either requires making the group table or some more sophisticated abstract algebra. Intuitively, the proof involves showing that there are three properties that each need to be permuted separately by some element—a rotation, a reflection about a vertical axis, and a reflection about a horizontal axis. Note that no pair of these

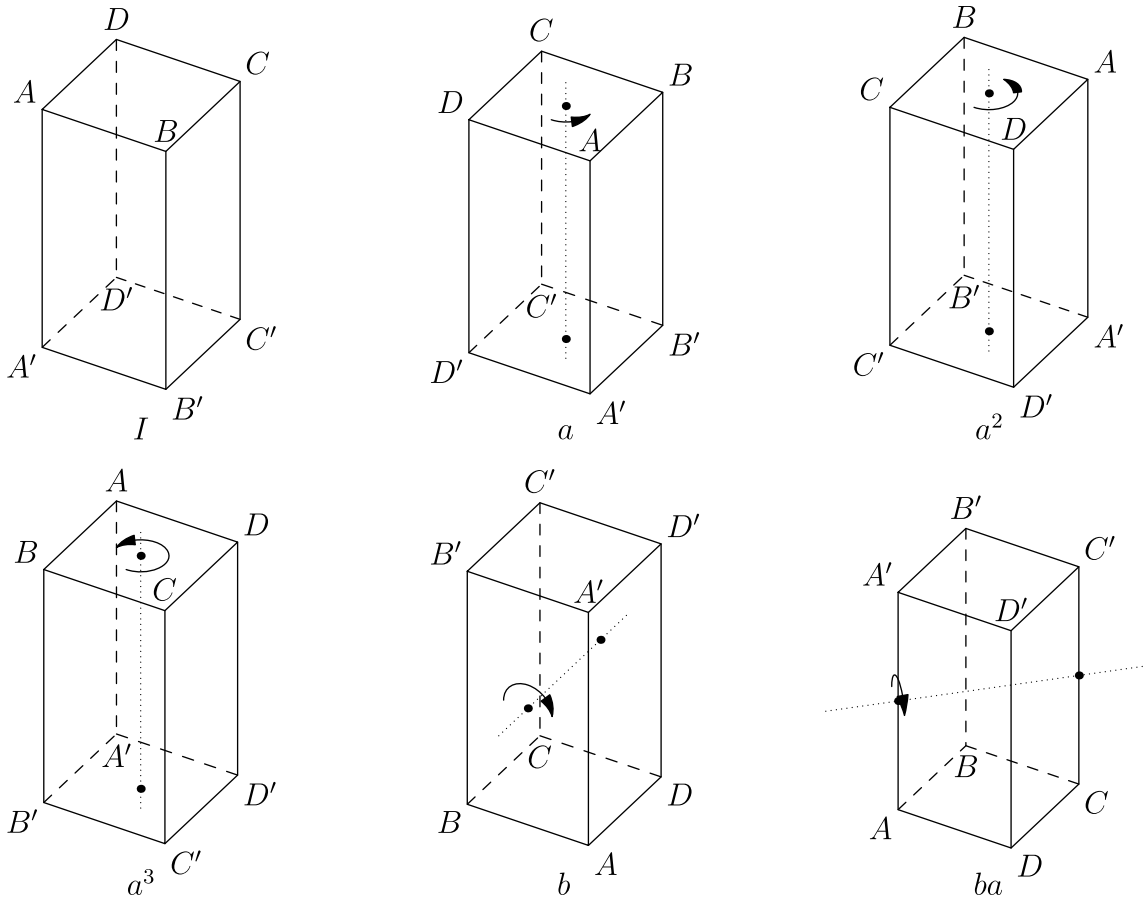

actions can generate the other. I will give a higher-level explanation for those who are well-versed in group theory already, but it will probably be nonsense to most.

The rotation group generated by $\{a, b\}$ is D_4 . Define a new element d which is the reflection through the midplane P between the two square faces.³ This is crudely shown in Figure 6; I couldn't be bothered to make a nicer figure. Then the reflection group generated by $\{d\}$ is Z_2 . Furthermore, the operation sets $\{a, b\}$ and $\{d\}$ are separable, in that $a^x b^y d = d a^x b^y$ ⁴. Thus, the group G described in this problem is (isomorphic to) the direct product:

$$G \cong D_4 \times Z_2.$$

We wish to show that $Z_2 \times Z_2 \times Z_2$ is a quotient of this group. That is, we wish to find a normal subgroup N such that

$$G/N = Z_2 \times Z_2 \times Z_2.$$

If this is true, then the minimal generating set of G has at least cardinality 3. All that remains is to find N and G/N .

It suffices to show that $Z_2 \times Z_2 \triangleleft D_4$, since then $Z_2 \times Z_2 \times Z_2 \triangleleft D_4 \times Z_2$. We have $|Z_2 \times Z_2| = 2^2 = 4$, so we want $|D_4/N| = 4$. We know $|D_4| = 8$, so by Lagrange's theorem, $|N| = 2$.

A normal subgroup of D_4 is $N = \{1, a^2\}$. It is normal because for $x \in \{0, 1, 2, 3\}$ and $y \in \{0, 1\}$:

³For the curious, $d = cba^2$.

⁴This can be shown concretely by simply showing geometrically that $ad = da$ and $bd = db$.

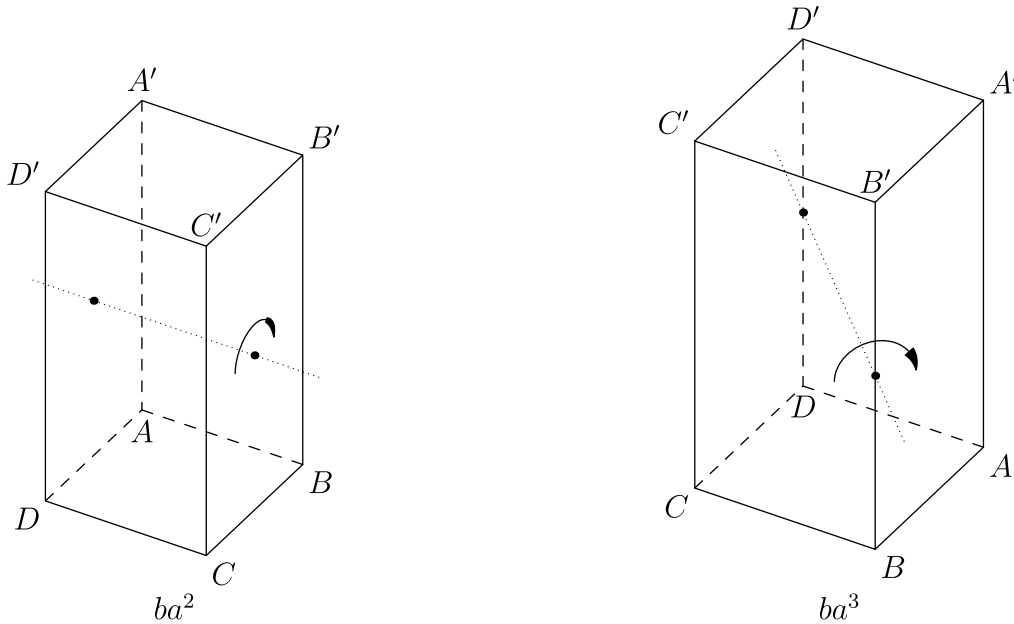

Figure 4: The elements of the rotation group of the rectangular prism.

$$\begin{aligned}
 (b^x a^y) a^2 (b^x a^y)^{-1} &= (b^x a^y) a^2 (a^{-y} b^{-x}) \\
 &= b^x a^{2+y-y} b^{-x} \\
 &= b^x a^2 b^{-x} \\
 &= b^x b^{-x} a^2 \\
 &= a^2 \in \{1, a^2\}.
 \end{aligned}$$

The corresponding quotient group is

$$D_4/N = \{\{1, a^2\}, \{a, a^3\}, \{b, ba^2\}, \{ba, ba^3\}\}.$$

We have the isomorphism $\{b^x a^y, b^x a^{y+2}\} \leftrightarrow (x, y)$ under the operation of element-wise addition modulo 2. After all,

$$\{b^{x_1} a^{y_1}, b^{x_1} a^{y_1+2}\} \cdot \{b^{x_2} a^{y_2}, b^{x_2} a^{y_2+2}\} = \{b^{x_1+x_2} a^{y_1+y_2}, b^{x_1+x_2} a^{y_1+y_2+2}\}.$$

Therefore,

$$D_4/N \cong Z_2 \times Z_2,$$

so

$$Z_2 \times Z_2 \times Z_2 \triangleleft D_4 \times Z_2 = G.$$

Since the minimal generating set of $Z_2 \times Z_2 \times Z_2$ is 3, G 's generating set has at least 3 elements. But we've already found the set $\{a, b, c\}$ which generates G !⁵ Thus, it is minimal.

(d) Whether the group is commutative

As we found in the previous problem, the rotation group of the square prism is not commutative, and since that's a subgroup of this group, this group certainly isn't commutative either.

11. Regular pentagon under rotation

(a) Number of elements

This group is just the cyclic group of order 5, so there are 5 elements.

(b) If order < 10, the set of elements; otherwise, an explanation of how you know the order

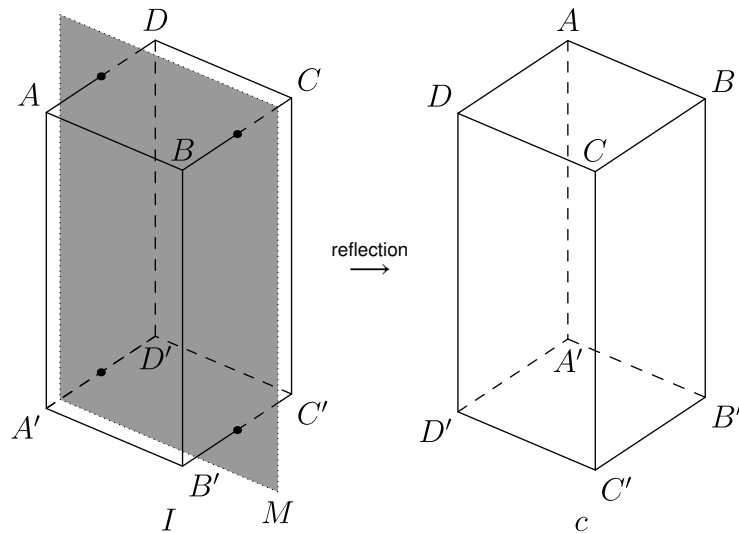

Figure 5: 3D reflection over the midplane M is c .

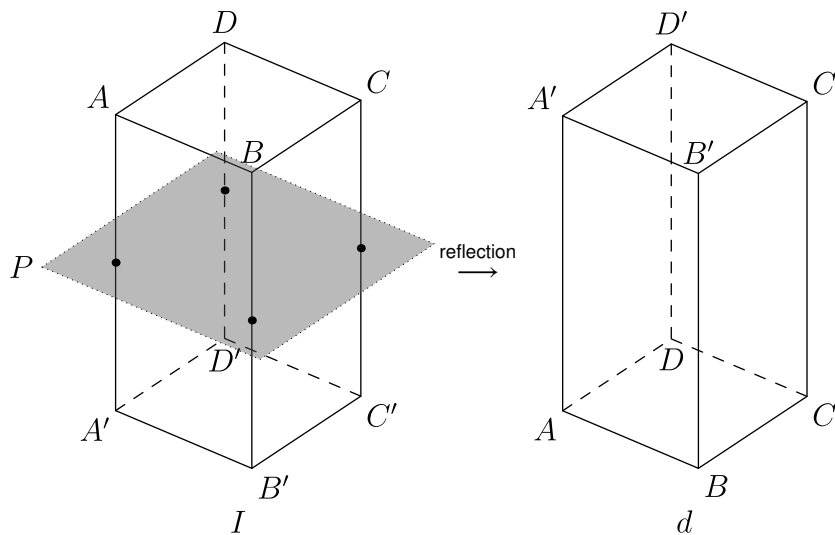

Figure 6: d is the reflection through midplane P .

The elements are rotations of $I = r_0$, $r = r_{72}$, $r^2 = r_{144}$, $r^3 = r_{216}$, $r^4 = r_{288}$. They are shown below. Pentagons should always wear helmets, lest they want to damage their vertices.

(c) A smallest possible generating set

Any rotation by itself $\{r^n\}$ works, since 5 is a prime.

(d) Whether the group is commutative

The group is indeed commutative, since all operations are two-dimensional rotations. (Note that in 3D, however, rotations do not commute!)

12. Regular pentagon under reflection

(a) Number of elements

This is the dihedral group of the pentagon, which has $2 \cdot 5 = 10$ elements.

⁵ $\{a, b, d\}$ also generates G .

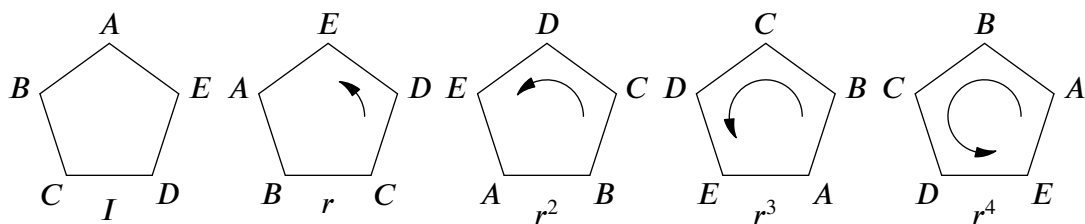

(b) If order < 10, the set of elements; otherwise, an explanation of how you know the order

We know the order because it should have twice the number of elements as the rotation group, which has 5 elements, giving 10 elements total.

(c) A smallest possible generating set

We can either do a rotation and a reflection or two reflections. Since 5 is prime, all pairs work (unlike for the square). Let f is a flip over the vertical axis. Examples of each are $\{r, f\}$ and $\{f, fr\}$.

(d) Whether the group is commutative

The group is not commutative. For example, $fr = fr$, but $rf = fr^4$.

13. Regular pentagonal prism under rotation

This group is isomorphic to the dihedral group of the pentagon, which is Problem 12. The reason is the same as for Problem 9's dependence on 8—see that answer for details.

14. Regular pentagonal prism under reflection

This problem is akin to Problem 10.

(a) Number of elements

$$2 \cdot 10 = 20.$$

(b) If order < 10, the set of elements; otherwise, an explanation of how you know the order

We know the order because the rotation group of the pentagonal prism has 10 elements, so its dihedral group has 20 elements.

(c) A smallest possible generating set

If a is a rotation of 72° about the central axis, b is a rotation of 180° about a horizontal axis, and d is a reflection across the midplane between the two pentagonal faces, then $\{a, b, d\}$ generates the set, since $\{a, b\}$ generates all rotations and d turns them into their mirror images. But this isn't the right answer.

Are there any smaller generating sets? We have $ad = da$ and $bd = db$ (you can verify this geometrically). So to have a two element subgroup we likely need something like $a^n d$ and ba^m for some integers n, m , so that we can potentially generate a, b and d .

Let's try ad and b . Taking successive powers of ad , we get

$$\begin{aligned} ad &= ad \\ (ad)^2 &= a^2 \\ (ad)^3 &= a^3 d \\ (ad)^4 &= a^4 \\ (ad)^5 &= a^5 d = d \\ (ad)^6 &= a \end{aligned}$$

We've just generated d and a from ad alone! Since we have b already, we have created $\{a, b, d\}$ from $\{ad, b\}$. Thus, the smallest generating set has size 2. (We can't have size 1 because then the group would be cyclic and thus commutative, which this group certainly isn't.)

This is a hard problem. Don't worry if you didn't get it.

(d) Whether the group is commutative

The dihedral group of the pentagon is a subgroup of this group, and is not commutative, so this group is not commutative.

15. Regular pentagonal pyramid under rotation

This is just isomorphic to the rotation group of the pentagon, or Problem 11.

16. Regular pentagonal pyramid under reflection

This is just isomorphic to the reflection group of the pentagon, or Problem 12.

17. Regular tetrahedron (triangular pyramid) under rotation

This is isomorphic to a *subgroup* of S_4 (order 24), and has order 12. This group is actually called the alternating group A_4 , and consists of even permutations of $(1, 2, 3, 4)$. An even permutation is a permutation generated by swapping an even number of pairs of elements. For example, $(1, 2, 4, 3)$ is an odd permutation (involving one swap), while $(2, 1, 4, 3)$ is an even permutation (involving two swaps).⁶

(a) Number of elements

The snap group includes reflections, but this group does not: Thus, this group has $\frac{4!}{2} = 12$ elements.

(b) If order < 10, the set of elements; otherwise, an explanation of how you know the order

We know the order because this is the rotation group of a tetrahedron, and the reflection group of a tetrahedron has 24 elements, so this groups must have half that count.

(c) A smallest possible generating set

Another difficult problem!

Let's figure out where the rotation axes actually are. There are 4 axes going through a vertex—let's call these *vertex* axes v_i . There are also 3 axes going through the midpoints of opposite edges: let's call these *edge* axes e_i . These axes are enumerated and shown in Figure 7.

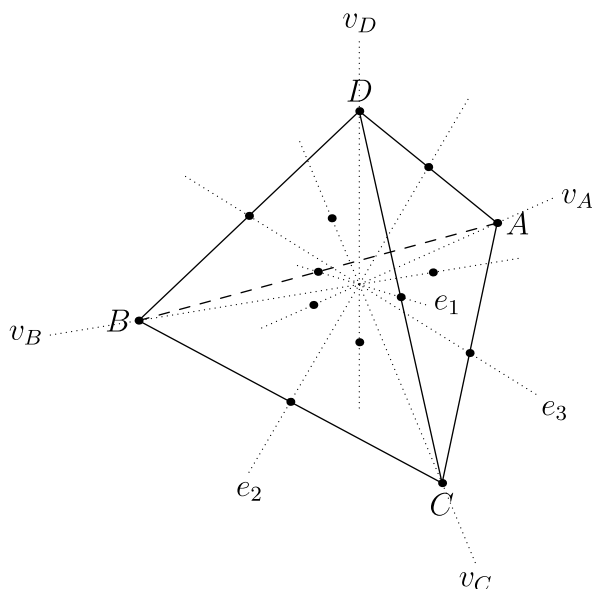

Figure 7: Regular tetrahedron's succulent rotation axes.

We can rotate by 120° or 240° (counterclockwise as viewed from the vertex) about any v_i , but only by 180° about any e_i . Along with the identity, this gives all $2 \cdot 4 + 3 + 1 = 12$ elements.

To make manipulating these elements easier, treat them as permuting vertices in a list. We name this list as shown in Figure 8. Thus, the identity element I is (A, B, C, D) . A rotation of 240° around v_A swaps vertices in positions $(3 \ 4)$ then $(2 \ 3)$, so $v_A = (A, D, B, C)$ as shown in Figure 9.

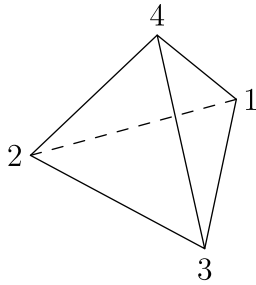

Figure 8: Regular tetrahedron's indices.

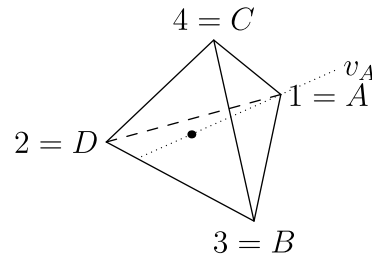

Figure 9: $v_A = (A, D, B, C)$.

If we take a look at an edge rotation, say e_1 , you will see it also swaps two vertices: in this case, $(3\ 4)$ and $(1\ 2)$. In general, any edge rotation or vertex rotation will swap two vertices—you can see this by plain symmetry or if you want, working it out for each rotation.

We now have a more abstract representation of this group: namely, it is the group of even permutations of (A, B, C, D) . For example, (B, A, D, C) is even, but (A, B, D, C) is not. The group operation is composing two permutations by chaining them together. Note that the identity, (A, B, C, D) is considered even, just as 0 is considered even.

One element is clearly not enough, because this group is not cyclic. Can we do it in two elements though?

Consider two vertex rotations, which cycle (without loss of generality) the first three vertices and the last three vertices. That is, $a = (3, 1, 2, 4)$ and $b = (1, 4, 2, 3)$. Can we get every even permutation with combinations of a and b ? Let's try list them out:

$$\begin{array}{llll}
 a = (3, 1, 2, 4), & a^2 = (2, 3, 1, 4), & a^3 = I = (1, 2, 3, 4), & b = (1, 4, 2, 3), \\
 b^2 = (1, 3, 4, 2), & b^3 = I = a^3, & ab = (2, 1, 4, 3), & ab^2 = (4, 1, 3, 2), \\
 a^2b = (4, 2, 1, 3), & a^2b^2 = (3, 4, 1, 2), & ba = a^2b^2, & b^2a = (3, 2, 4, 1), \\
 ba^2 = (2, 4, 3, 1), & b^2a^2 = ab, & b^2a^2 = a^2, & b^2ab = ba^2, \\
 b^2a^2 = a^2b, & b^2ab^2 = (4, 3, 2, 1) = ba^2b & &
 \end{array}$$

We have successfully generated all 12 elements with the set $\{a, b\}$. Thus, a two element generating set is sufficient! Interestingly, this means you can turn a tetrahedron however you want by holding it at two corners and twisting it with each.

For the curious, this group is the alternating group A_4 .

(d) Whether the group is commutative

The group is clearly not commutative, since $ab \neq ba$. Unlike in two dimensions, rotations in 3D generally do not commute!

18. Regular tetrahedron under reflection

This is just the snap group of order 4, S_4 .

(a) Number of elements

As we found in the first problem, S_4 has $4! = 24$ elements.

(b) If order < 10, the set of elements; otherwise, an explanation of how you know the order

As we found in the first problem, S_4 has $4! = 24$ elements.

(c) A smallest possible generating set

This problem is tricky.

The obvious thing to do is keep $\{a, b\}$ from the previous problem and add some reflection c . Then $\{a, b, c\}$ has all 24 elements, since $\{a, b\}$ makes 12 elements and c makes a copy of each "in the mirror world." This is not, however, the right answer.

⁶The parity of a permutation is of great importance in group theory; Wikipedia has a decent article on the topic.

A generating of 2 elements is actually possible! There are several ways to see this, but I find a permutation argument easiest to follow.

S_4 is not just the reflection group of the tetrahedron, but also the group of all permutations of $(1, 2, 3, 4)$. Consider the permutation $j = (4, 1, 2, 3)$, which cycles all the elements, and the permutation $k = (2, 1, 3, 4)$, which swaps the first elements. Then

$$j = (4, 1, 2, 3), \quad j^2 = (3, 4, 1, 2), \quad j^3 = (2, 3, 4, 1), \quad j^4 = I = (1, 2, 3, 4).$$

We can flip any two adjacent elements (as well as the first and last elements) by doing the following:

1. Cycle using powers of j until the two elements in question are the first two elements.
2. Swap them with an application of k .
3. Cycle back to the starting position with powers of j .

In more mathematical terms, we can swap indices i and $i + 1$, where $1 \leq i \leq 3$, with the following element.

$$j^{i-1} k j^{5-i}.$$

Intuitively, if you can swap any two *adjacent* elements, you can make any permutations—not just the even ones—and thus generate the full group.

Let's see what the elements j and k actually are, operating on the tetrahedron.

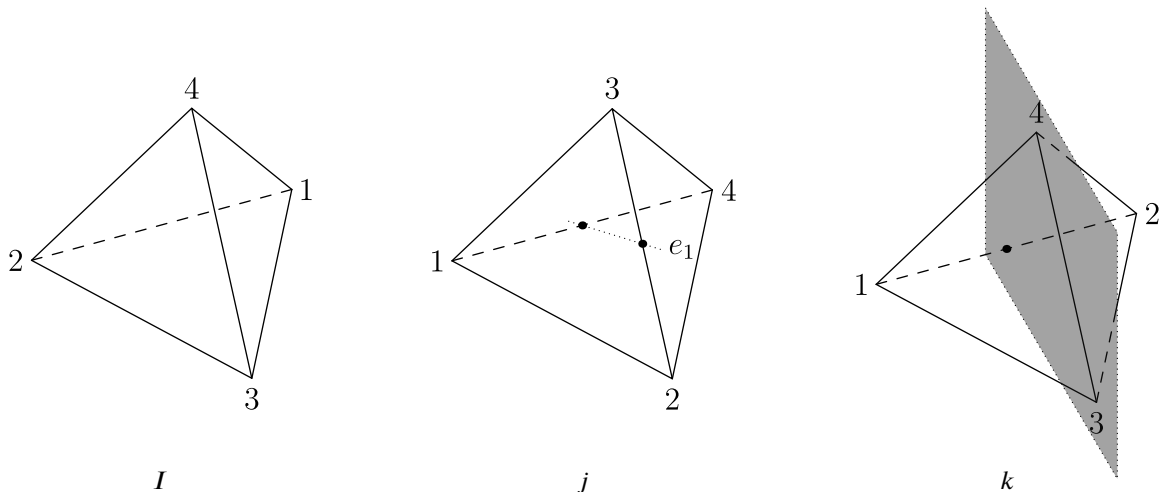

Figure 10: The two elements j and k generate the full symmetry group of the tetrahedron.

Thus, the true minimal generating set is $\{j, k\}$ as described.

(d) Whether the group is commutative

This group is certainly not commutative, since the previous group from Problem 17 was not commutative and is a subgroup of this group.

19. Cube under rotation

There are a couple ways to analyze this. My favorite one is to choose a face to make the top face, which can be done in 6 ways, then choose which rotation that face should be in, which can be done in 4 ways.

(a) Number of elements

Since we choose a front face in 6 ways, and its rotations in 4 ways, we have $6 \cdot 4 = 24$ total rotations.

(b) If order < 10 , the set of elements; otherwise, an explanation of how you know the order

The order is found above.

(c) A smallest possible generating set

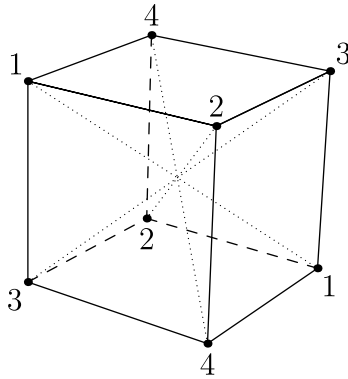

Figure 11: Marking opposite pairs of vertices.

This problem is tough without a simplifying observation. If we label space-diagonally opposite vertices (in other words, vertices which don't share a face) with the same number, as shown in Figure 11, then we can easily enumerate valid rotations.

The front face starts off saying "1,2,3,4." I claim that the $4!$ permutations of these four labels on the front face yields every rotation, and only rotations.

First, note that you will always see the numbers "1,2,3,4" in *some order* on the front face; you cannot see two of one number because all numbers are placed on diagonals of each other, and never share a side.

Second, note that the list of four numbers on the front face uniquely determines the other labels, since each has exactly one pair on the back face. For example, if there is a 3 in the closest corner to the camera, then there *must* be a 3 in the furthest corner of the camera.

Third, we demonstrate that the permutation of labels can always be represented as a rotation. There are six fundamentally different types of label squares under rotation *rotation*, as shown in Figure 12. But all appear somewhere as a face on the cube, as shown in Figure 13.

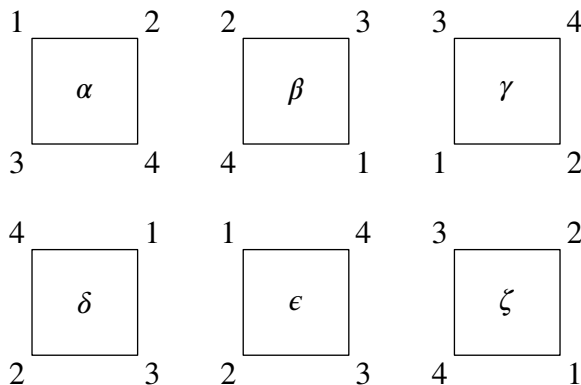

Figure 12: The six different labelings of a square.

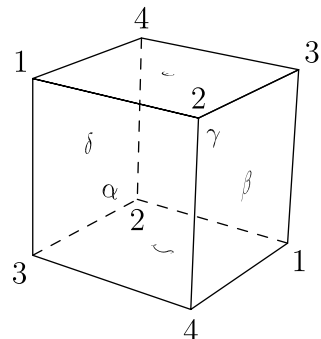

Figure 13: The six different labelings indeed appear on the cube!

We have demonstrated that every permutation of the front face labels creates a unique orientation of the cube, and that each such orientation is a rotation. Since there are 24 unique permutations and 24 unique rotations, every rotation has exactly one corresponding permutation and vice versa. We can now construct an isomorphism! The set of label permutations under the operation of composing permutations (as we did with the tetrahedron) and the set of rotations under the operation of composing rotations are isomorphic.

So the group of rotations of a cube is actually S_4 , the permutation group of 4 elements. (I find this fact incredible.)

Back to the main question: what is the minimal generating set? In the previous question, we found that the permutations $(4, 1, 2, 3)$ —cycling all elements forward—and $(2, 1, 3, 4)$ —swapping the first two elements—generate S_4 . For the cube, those are two rotations a and b as shown in Figure 14.

(d) Whether the group is commutative

This group is not commutative, since S_4 is not commutative.

20. Cube under reflection

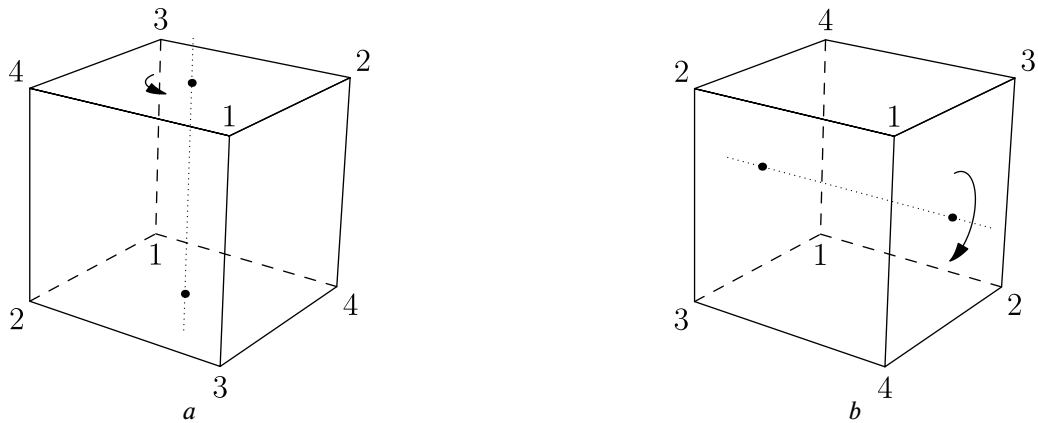

Figure 14: The two rotations a and b .

(a) Number of elements

There are 24 elements in the rotation group of the cube, so naturally there are 48 elements in the reflection group.

(b) If order < 10, the set of elements; otherwise, an explanation of how you know the order

For each of the 24 rotations of the cube, there is also a reflected version over some plane. This gives $2 \cdot 24 = 48$ total elements in this group.

(c) A smallest possible generating set

If c is a reflection about, say, the origin of the cube, then $\{a, b, c\}$ (where a, b are the rotations from before) would generate the whole group, since $\{a, b\}$ generates all rotations and $\{c\}$ generates their respective reflections. But can we do it in two?

The answer is yes! The proof is not mine, because I couldn't figure it out, but due to math.SE user **verret**. It does require some more advanced concepts, so it is probably inaccessible to most.

The group we've been analyzing is $S_4 \times Z_2$. Let S_4 be permuting elements $\{1, 2, 3, 4\}$ and Z_2 be permuting elements $\{5, 6\}$ (note that $Z_2 = S_2$). Then given two elements $g = (4, 1, 2, 3, 5, 6)$ in our notation, meaning that indices $(1, 2, 3, 4)$ are cycled, and $h = (3, 1, 2, 4, 6, 5)$, meaning that indices $(1, 2, 3)$ and $(5, 6)$ are cycled, we can construct the group.

Note that $h^2 = (2, 3, 1, 5, 6)$ is in S_4 , since it does not permute indices $5, 6$. It has a period of 3, and thus generates a subgroup of order 3. Furthermore, h^3 only permutes $(5, 6)$. Furthermore, g is an element in S_4 and has a period of 4. Thus, since $\text{gcd}(3, 4) = 1$, by Lagrange's theorem we know that $\{h^2, g\}$ generates a subgroup of S_4 of at least order $3 \cdot 4 = 12$.

The only such subgroup, besides S_4 itself, is the alternating group A_4 . But g is outside of A_4 , since it is an odd permutation:

$$(1, 2, \boxed{3, 4}) \rightarrow (1, \boxed{2, 4}, 3) \rightarrow (\boxed{1, 4}, 2, 3) \rightarrow (4, 1, 2, 3).$$

Thus, $\{h^2, g\}$ does not generate A_4 , and must generate S_4 . Adding h^3 , the generator for Z_2 , to this set gives the full S_4, Z_2 . The minimal generating set is therefore $\{g, h\}$ as defined.

For the curious, using our vertex "labeling" convention as before, the elements g and h are shown in Figure 15.

(d) Whether the group is commutative

The subgroup of rotations of the cube, S_4 , is not commutative, so this group is definitely not commutative.

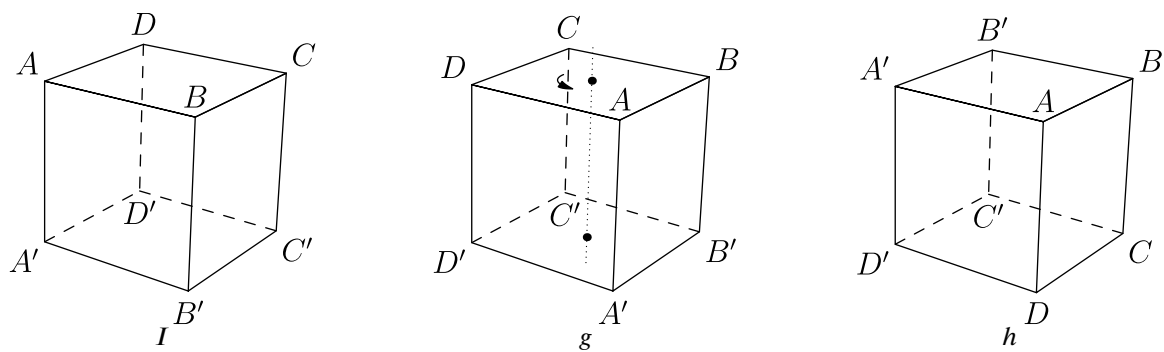

Figure 15: Elements g and h . Note that h is not solely a reflection about a mirror plane, but actually a combination of a rotation and reflection: a so-called rotoinversion!